

37032 RG



LM117/217
LM317

1.2V TO 37V VOLTAGE REGULATOR

- OUTPUT VOLTAGE RANGE: 1.2 TO 37V
- OUTPUT CURRENT IN EXCESS OF 1.5A
- 0.1% LINE AND LOAD REGULATION
- FLOATING OPERATION FOR HIGH VOLTAGES
- COMPLETE SERIES OF PROTECTIONS: CURRENT LIMITING, THERMAL SHUTDOWN AND SOA CONTROL

DESCRIPTION

The LM117/LM217/LM317 are monolithic integrated circuit in TO-220, TO-220FP, TO-3 and D²PAK packages intended for use as positive adjustable voltage regulators.

They are designed to supply more than 1.5A of load current with an output voltage adjustable over a 1.2 to 37V range.

The nominal output voltage is selected by means of only a resistive divider, making the device exceptionally easy to use and eliminating the stocking of many fixed regulators.

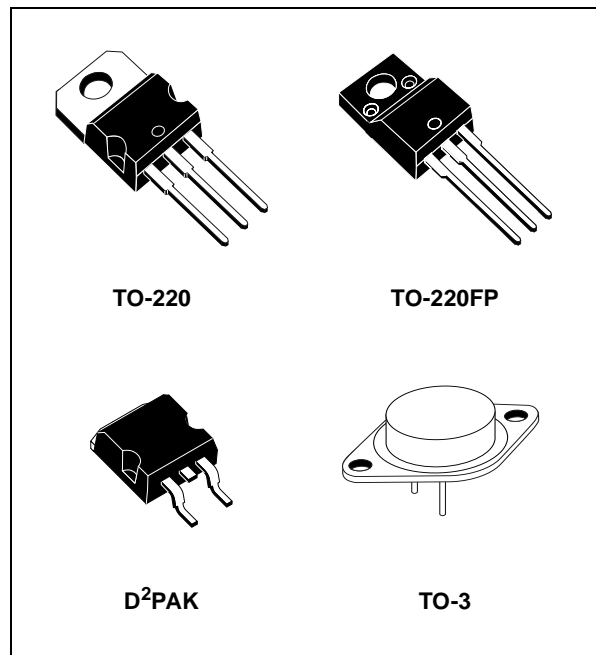

SCHEMATIC DIAGRAM

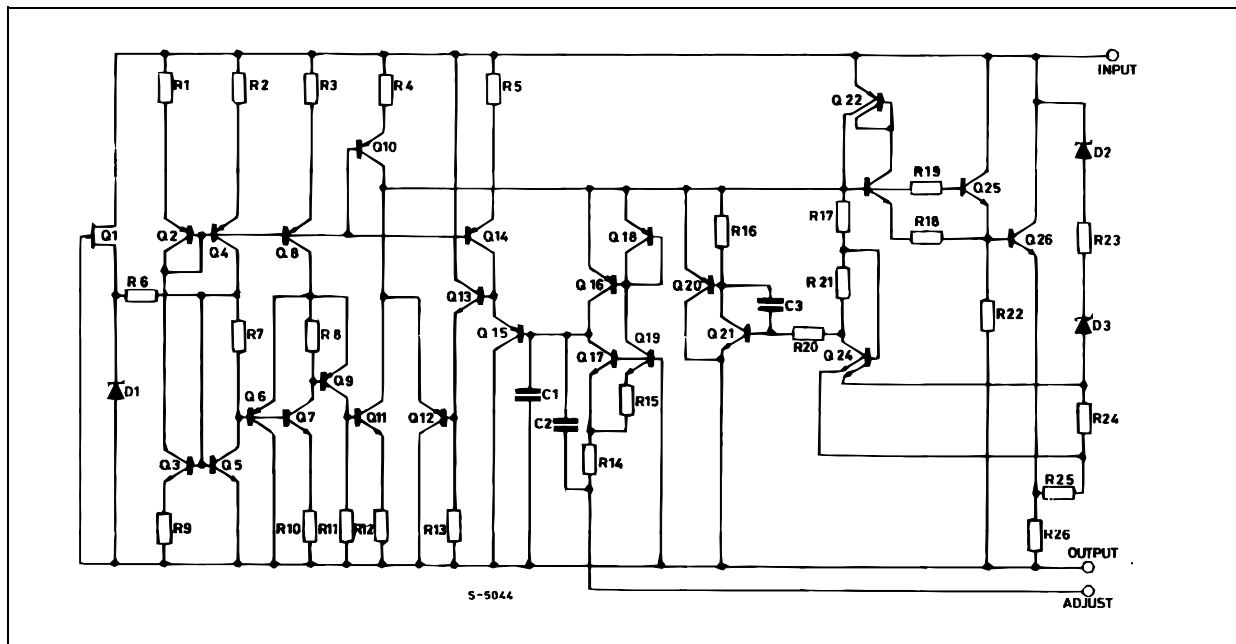

LM117/217/317

ABSOLUTE MAXIMUM RATINGS

Symbol	Parameter	Value	Unit
$V_I - V_{REF}$	Input-Reference Differential Voltage	40	V
I_O	Output Current	Internally Limited	
T_{op}	Operating Junction Temperature for:	LM117	-55 to 150
		LM217	-25 to 150
		LM317	0 to 125
P_{tot}	Power Dissipation	Internally Limited	
T_{stg}	Storage Temperature	-65 to 150	°C

Absolute Maximum Ratings are those values beyond which damage to the device may occur. Functional operation under these condition is not implied.

THERMAL DATA

Symbol	Parameter	D ² PAK	TO-220	TO-220FP	TO-3	Unit
$R_{thj-case}$	Thermal Resistance Junction-case Max	3	3	5	4	°C/W
$R_{thj-amb}$	Thermal Resistance Junction-ambient Max	62.5	50	60	35	°C/W

CONNECTION DIAGRAM (top view)

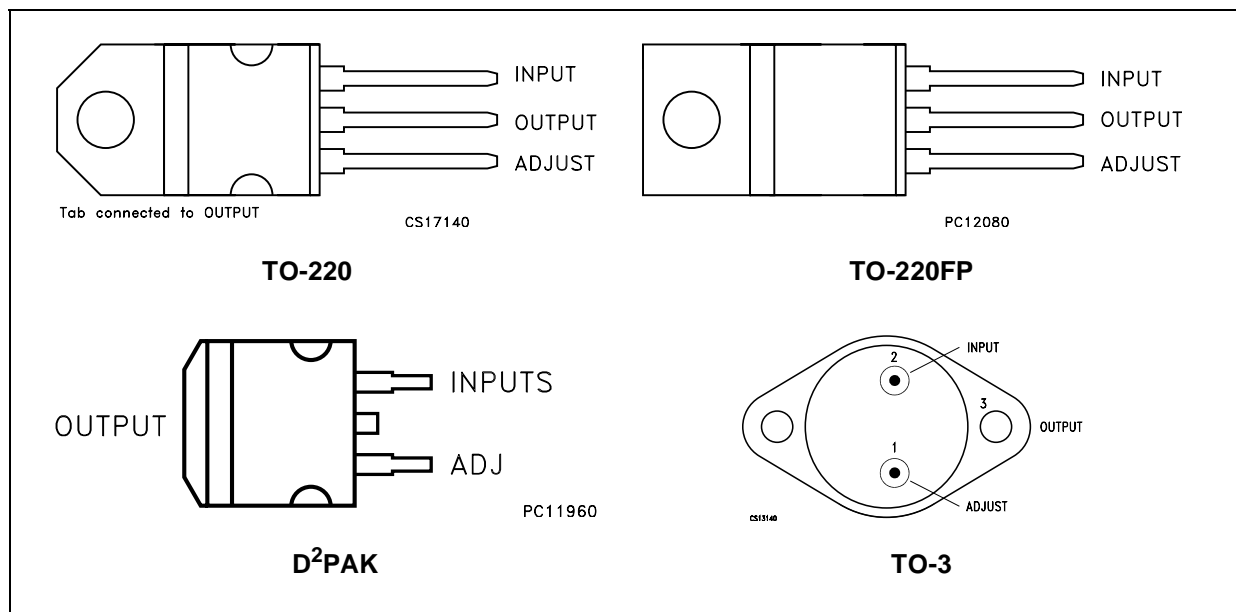

ORDERING CODES

TYPE	TO-220	D ² PAK	TO-220FP	TO-3
LM117				LM117K
LM217	LM217T	LM217D2T		LM217K
LM317	LM317T	LM317D2T	LM317P	LM317K

BASIC ADJUSTABLE REGULATOR

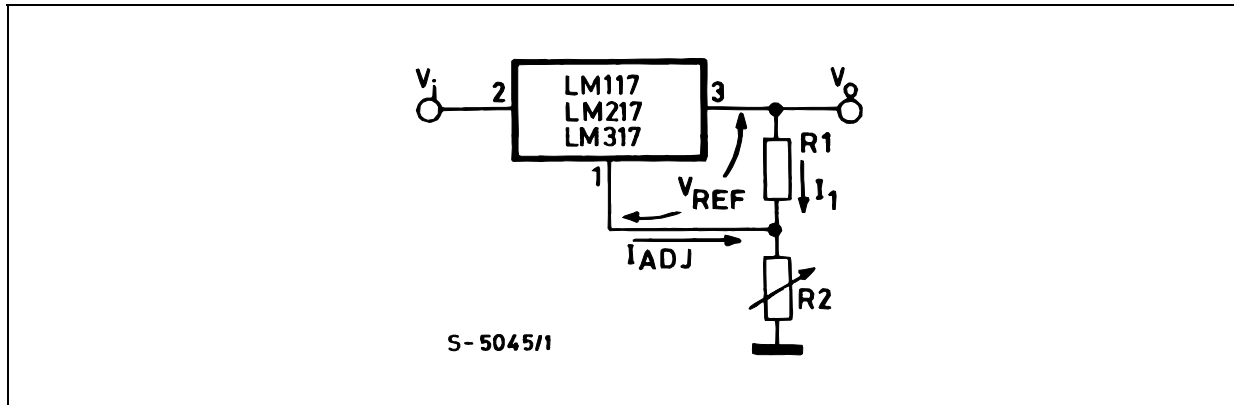

ELECTRICAL CHARACTERISTICS FOR LM117/LM217 ($V_I - V_{REF} = 5\text{ V}$, $I_O = 500\text{ mA}$, $I_{MAX} = 1.5\text{ A}$ and $P_{MAX} = 20\text{ W}$, $T_J = -55\text{ to }150^\circ\text{C}$ for LM117, $T_J = -25\text{ to }150^\circ\text{C}$ for LM217, unless otherwise specified).

Symbol	Parameter	Test Conditions	Min.	Typ.	Max.	Unit	
ΔV_O	Line Regulation	$V_I - V_{REF} = 3\text{ to }40\text{ V}$ $T_J = 25^\circ\text{C}$		0.01	0.02	%V	
				0.02	0.05		
ΔV_O	Load Regulation	$V_O \leq 5\text{ V}$ $I_O = 10\text{ mA to }I_{MAX}$ $T_J = 25^\circ\text{C}$		5	15	mV	
				20	50		
		$V_O \geq 5\text{ V}$ $I_O = 10\text{ mA to }I_{MAX}$ $T_J = 25^\circ\text{C}$		0.1	0.3	%	
				0.3	1		
I_{ADJ}	Adjustment Pin Current			50	100	μA	
ΔI_{ADJ}	Adjustment Pin Current	$V_I - V_{REF} = 2.5\text{ to }40\text{V}$ $I_O = 10\text{ mA to }I_{MAX}$		0.2	5	μA	
V_{REF}	Reference Voltage (between pin 3 and pin 1)	$V_I - V_{REF} = 2.5\text{ to }40\text{V}$ $I_O = 10\text{ mA to }I_{MAX}$ $P_D \leq P_{MAX}$	1.2	1.25	1.3	V	
$\Delta V_O/V_O$	Output Voltage Temperature Stability			1		%	
$I_{O(min)}$	Minimum Load Current	$V_I - V_{REF} = 40\text{ V}$		3.5	5	mA	
$I_{O(max)}$	Maximum Load Current	$V_I - V_{REF} \leq 15\text{ V}$ $P_D < P_{MAX}$	1.5	2.2		A	
		$V_I - V_{REF} = 40\text{ V}$ $P_D < P_{MAX}$ $T_J = 25^\circ\text{C}$		0.4			
eN	Output Noise Voltage (percentage of V_O)	$B = 10\text{Hz to }100\text{KHz}$ $T_J = 25^\circ\text{C}$		0.003		%	
SVR	Supply Voltage Rejection (*)	$T_J = 25^\circ\text{C}$ $f = 120\text{Hz}$	$C_{ADJ}=0$		65		dB
			$C_{ADJ}=10\mu\text{F}$	66	80		

(*) C_{ADJ} is connected between pin 1 and ground.

ELECTRICAL CHARACTERISTICS FOR LM317 ($V_I - V_{REF} = 5\text{ V}$, $I_O = 500\text{ mA}$, $I_{MAX} = 1.5\text{ A}$ and $P_{MAX} = 20\text{ W}$, $T_J = 0\text{ to }125^\circ\text{C}$, unless otherwise specified).

Symbol	Parameter	Test Conditions	Min.	Typ.	Max.	Unit
ΔV_O	Line Regulation	$V_I - V_{REF} = 3\text{ to }40\text{ V}$	$T_J = 25^\circ\text{C}$	0.01	0.04	%V
				0.02	0.07	
ΔV_O	Load Regulation	$V_O \leq 5\text{ V}$ $I_O = 10\text{ mA to }I_{MAX}$	$T_J = 25^\circ\text{C}$	5	25	mV
				20	70	
		$V_O \geq 5\text{ V}$ $I_O = 10\text{ mA to }I_{MAX}$	$T_J = 25^\circ\text{C}$	0.1	0.5	%
				0.3	1.5	
I_{ADJ}	Adjustment Pin Current			50	100	μA
ΔI_{ADJ}	Adjustment Pin Current	$V_I - V_{REF} = 2.5\text{ to }40\text{ V}$ $I_O = 10\text{ mA to }I_{MAX}$		0.2	5	μA
V_{REF}	Reference Voltage (between pin 3 and pin 1)	$V_I - V_{REF} = 2.5\text{ to }40\text{ V}$ $I_O = 10\text{ mA to }I_{MAX}$ $P_D \leq P_{MAX}$	1.2	1.25	1.3	V
$\Delta V_O/V_O$	Output Voltage Temperature Stability			1		%
$I_{O(min)}$	Minimum Load Current	$V_I - V_{REF} = 40\text{ V}$		3.5	10	mA
$I_{O(max)}$	Maximum Load Current	$V_I - V_{REF} \leq 15\text{ V}$ $P_D < P_{MAX}$	1.5	2.2		A
		$V_I - V_{REF} = 40\text{ V}$ $P_D < P_{MAX}$ $T_J = 25^\circ\text{C}$		0.4		
eN	Output Noise Voltage (percentage of V_O)	$B = 10\text{ Hz to }100\text{ KHz}$ $T_J = 25^\circ\text{C}$		0.003		%
SVR	Supply Voltage Rejection (*)	$T_J = 25^\circ\text{C}$ $f = 120\text{ Hz}$	$C_{ADJ}=0$		65	dB
			$C_{ADJ}=10\mu\text{F}$	66	80	

(*) C_{ADJ} is connected between pin 1 and ground.

Figure 1 : Output Current vs Input-output Differential Voltage

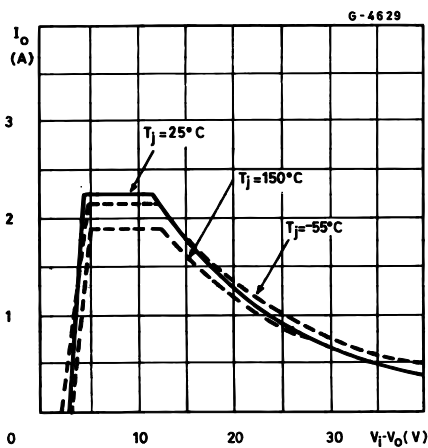

Figure 2 : Dropout Voltage vs Junction Temperature

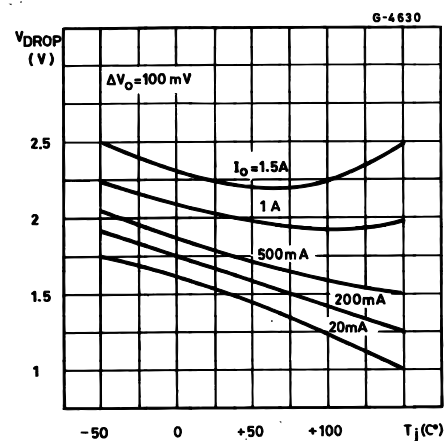

Figure 3 : Reference Voltage vs Junction

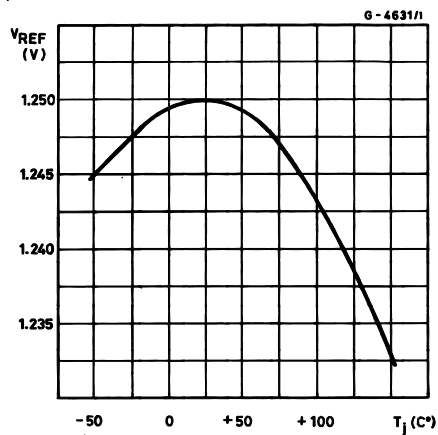
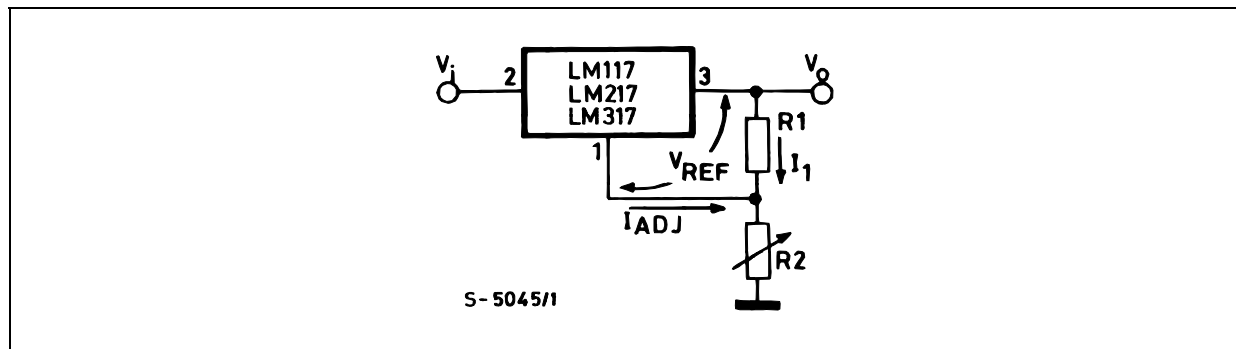

Figure 4 : Basic Adjustable Regulator



APPLICATION INFORMATION

The LM117/217/317 provides an internal reference voltage of 1.25V between the output and adjustments terminals. This is used to set a constant current flow across an external resistor divider (see fig. 4), giving an output voltage V_O of:

$$V_O = V_{REF} (1 + R_2/R_1) + I_{ADJ} R_2$$

The device was designed to minimize the term I_{ADJ} (100 μ A max) and to maintain it very constant with line and load changes. Usually, the error term $I_{ADJ} \times R_2$ can be neglected. To obtain the previous requirement, all the regulator quiescent current is returned to the output terminal, imposing a minimum load current condition. If the load is insufficient, the output voltage will rise. Since the LM117/217/317 is a floating regulator and "sees" only the input-to-output differential voltage, supplies of very high voltage with respect to ground can be regulated as long as the maximum input-to-output differential is not exceeded. Furthermore, programmable regulators are easily obtainable and, by connecting a fixed resistor between the adjustment and output, the device can be used as a precision current regulator. In order to optimize the load regulation, the current set resistor R_1 (see fig. 4) should be tied as close as possible to the regulator, while the ground terminal of R_2 should be near the ground of the load to provide remote ground sensing. Performance may be improved with added capacitance as follows:

An input bypass capacitor of 0.1 μ F

An adjustment terminal to ground 10 μ F capacitor to improve the ripple rejection of about 15 dB (C_{ADJ}).

A 1 μ F tantalum (or 25 μ F aluminium electrolytic) capacitor on the output to improve transient response. In addition to external capacitors, it is good practice to add protection diodes, as shown in fig. 5. D1 protects the device against input short circuit, while D2 protects against output short circuit for capacitance discharging.

Table 5 : Voltage Regulator with Protection Diodes

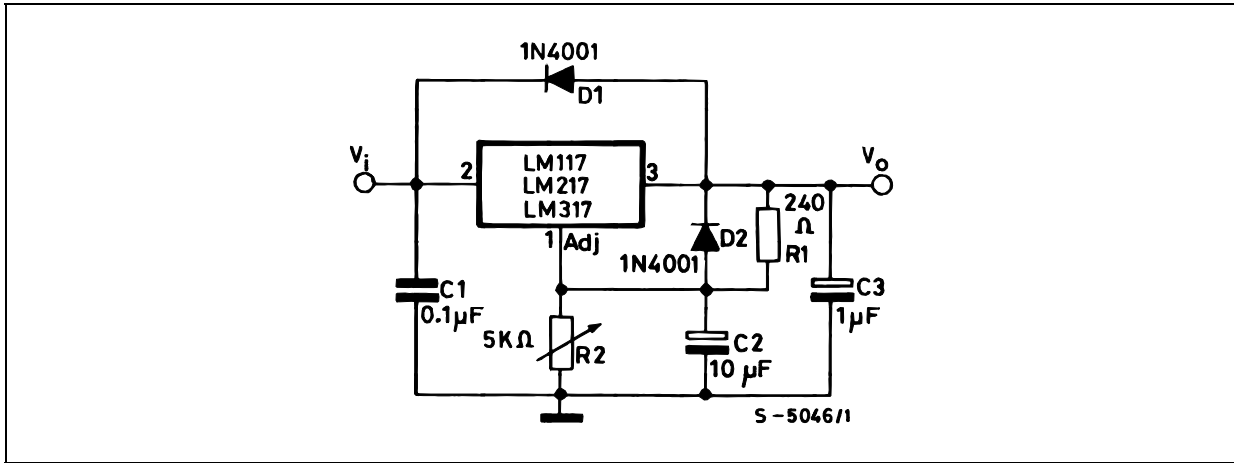

D1 protect the device against input short circuit, while D2 protects against output short circuit for capacitors discharging.

Figure 6 : Slow Turn-on 15V Regulator

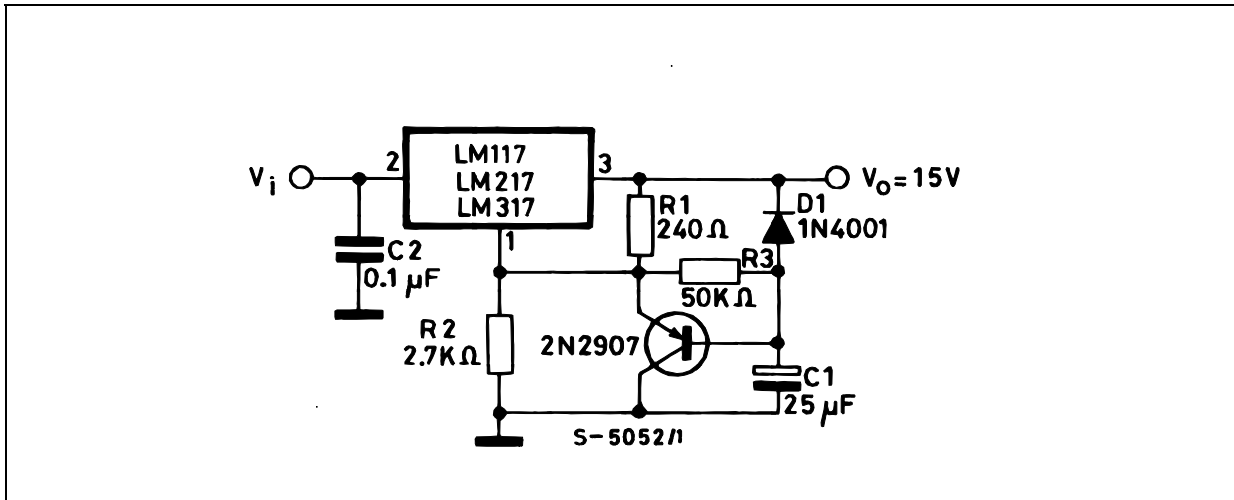

Figure 7 : Current Regulator

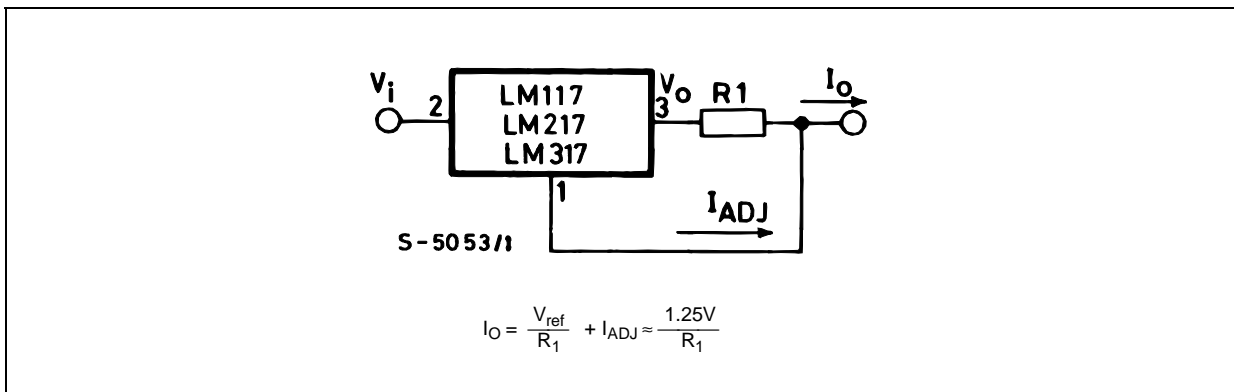

Figure 8 : 5V Electronic Shut-down Regulator

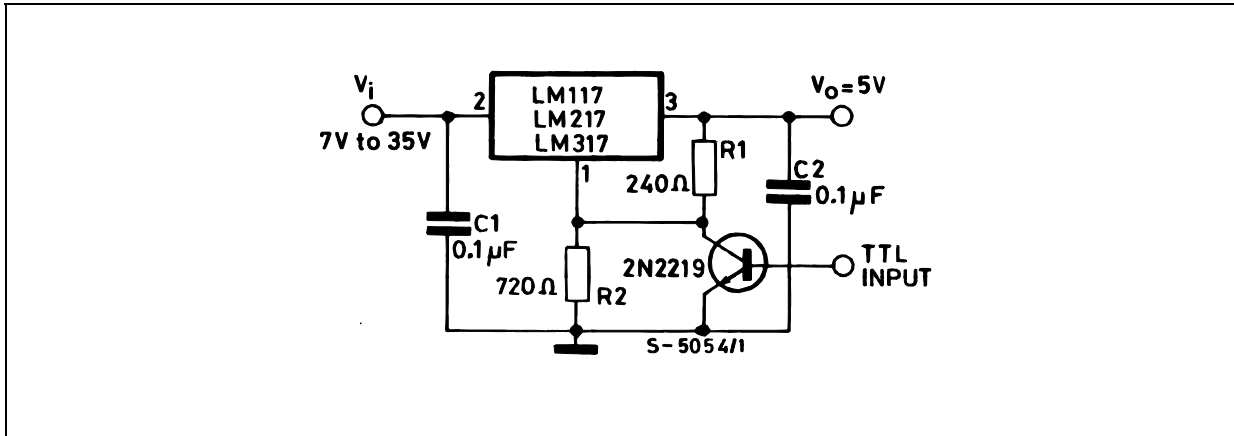
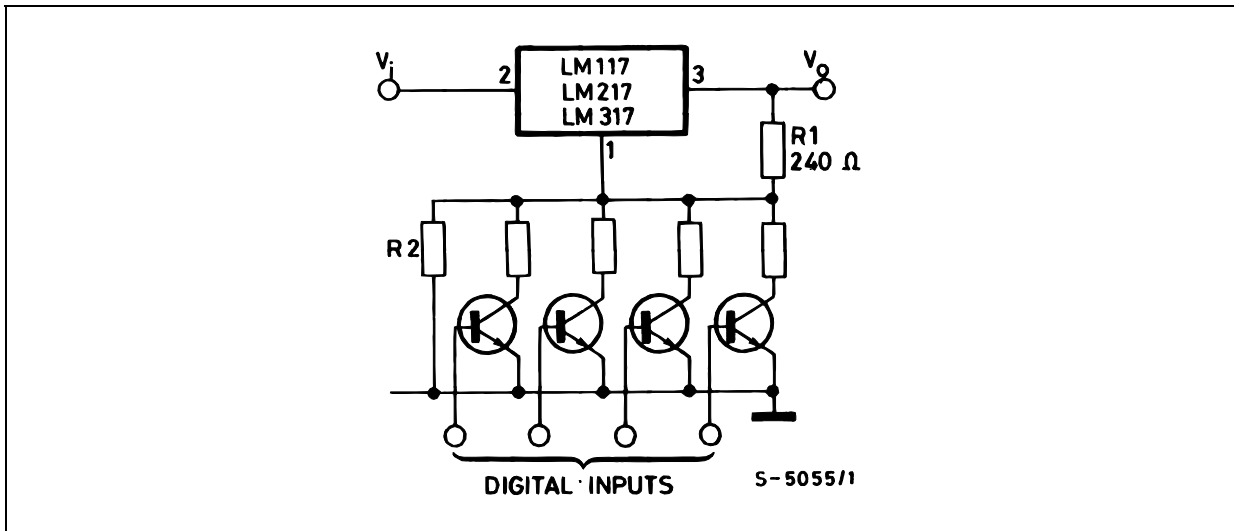
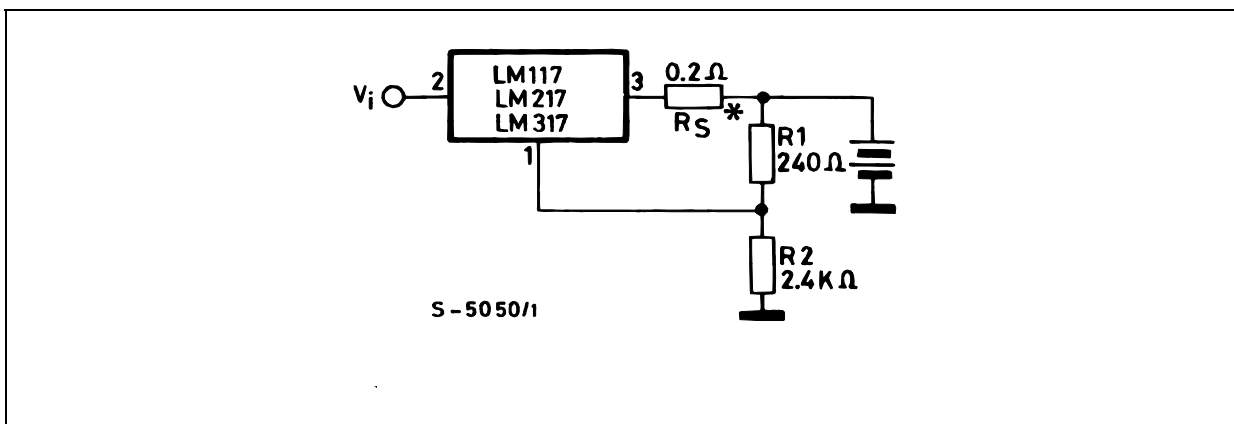

Figure 9 : Digitally Selected Outputs



(R₂ sets maximum V_O)

Figure 10 : Battery Charger (12V)



* R_S sets output impedance of charger $Z_O = R_S (1 + R_2/R_1)$. Use of R_S allows low charging rates whit fully charged battery.

Figure 11 : Current Limited 6V Charger

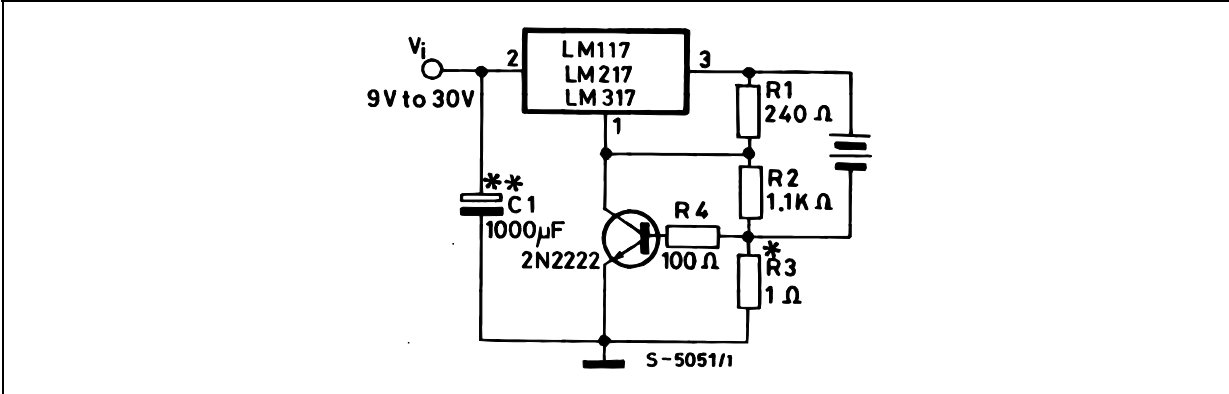

* R_3 sets peak current (0.6A for 1 Ω).
** C_1 recommended to filter out input transients

TO-3 MECHANICAL DATA

DIM.	mm.			inch		
	MIN.	TYP.	MAX.	MIN.	TYP.	MAX.
A		11.85			0.466	
B	0.96	1.05	1.10	0.037	0.041	0.043
C			1.70			0.066
D			8.7			0.342
E			20.0			0.787
G		10.9			0.429	
N		16.9			0.665	
P			26.2			1.031
R	3.88		4.09	0.152		0.161
U			39.5			1.555
V		30.10			1.185	

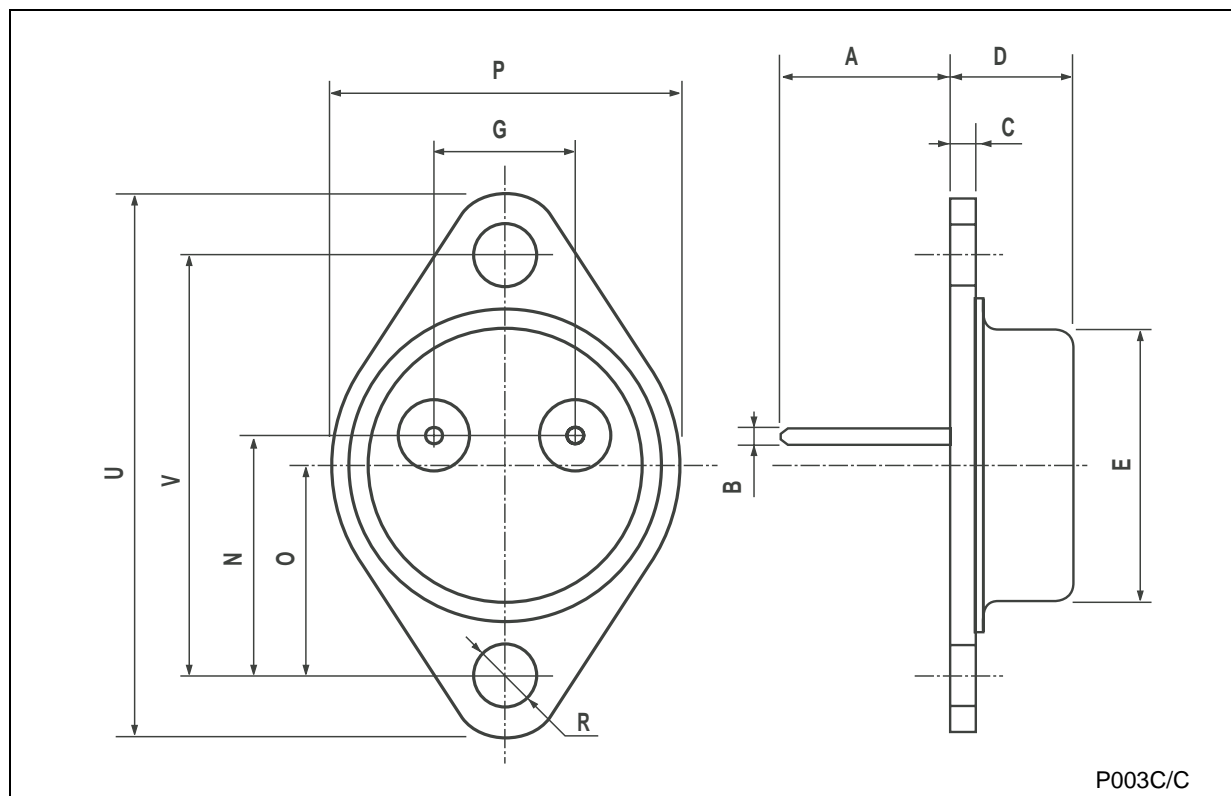

TO-220 MECHANICAL DATA

DIM.	mm.			inch		
	MIN.	TYP	MAX.	MIN.	TYP.	MAX.
A	4.40		4.60	0.173		0.181
C	1.23		1.32	0.048		0.051
D	2.40		2.72	0.094		0.107
D1		1.27			0.050	
E	0.49		0.70	0.019		0.027
F	0.61		0.88	0.024		0.034
F1	1.14		1.70	0.044		0.067
F2	1.14		1.70	0.044		0.067
G	4.95		5.15	0.194		0.203
G1	2.4		2.7	0.094		0.106
H2	10.0		10.40	0.393		0.409
L2		16.4			0.645	
L4	13.0		14.0	0.511		0.551
L5	2.65		2.95	0.104		0.116
L6	15.25		15.75	0.600		0.620
L7	6.2		6.6	0.244		0.260
L9	3.5		3.93	0.137		0.154
DIA.	3.75		3.85	0.147		0.151

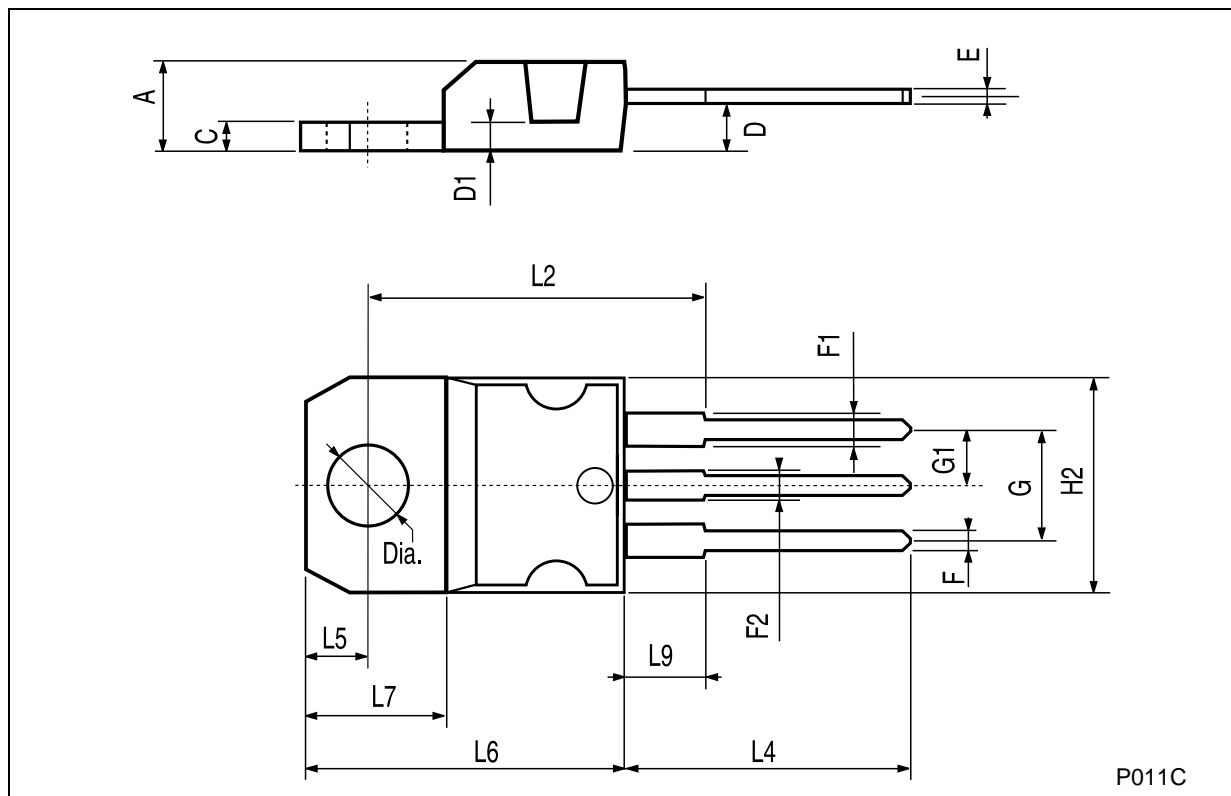

TO-220FP MECHANICAL DATA

DIM.	mm.			inch		
	MIN.	TYP.	MAX.	MIN.	TYP.	MAX.
A	4.40		4.60	0.173		0.181
B	2.5		2.7	0.098		0.106
D	2.5		2.75	0.098		0.108
E	0.45		0.70	0.017		0.027
F	0.75		1	0.030		0.039
F1	1.15		1.50	0.045		0.059
F2	1.15		1.50	0.045		0.059
G	4.95		5.2	0.194		0.204
G1	2.4		2.7	0.094		0.106
H	10.0		10.40	0.393		0.409
L2		16			0.630	
L3	28.6		30.6	1.126		1.204
L4	9.8		10.6	0.385		0.417
L6	15.9		16.4	0.626		0.645
L7	9		9.3	0.354		0.366
DIA.	3		3.2	0.118		0.126

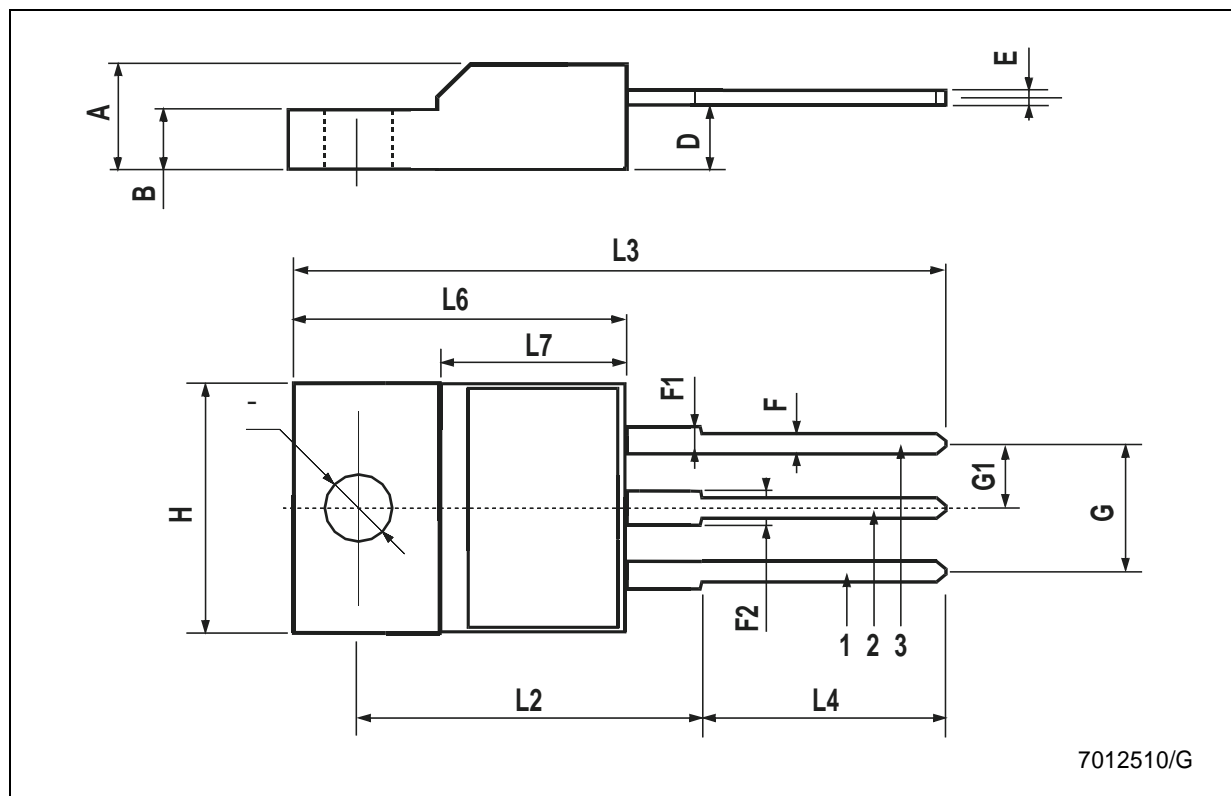

D²PAK MECHANICAL DATA

DIM.	mm.			inch		
	MIN.	TYP	MAX.	MIN.	TYP.	MAX.
A	4.4		4.6	0.173		0.181
A1	2.49		2.69	0.098		0.106
A2	0.03		0.23	0.001		0.009
B	0.7		0.93	0.027		0.036
B2	1.14		1.7	0.044		0.067
C	0.45		0.6	0.017		0.023
C2	1.23		1.36	0.048		0.053
D	8.95		9.35	0.352		0.368
D1		8			0.315	
E	10		10.4	0.393		0.409
E1		8.5			0.335	
G	4.88		5.28	0.192		0.208
L	15		15.85	0.590		0.624
L2	1.27		1.4	0.050		0.055
L3	1.4		1.75	0.055		0.068
M	2.4		3.2	0.094		0.126
R		0.4			0.016	
V2	0°		8°	0°		8°

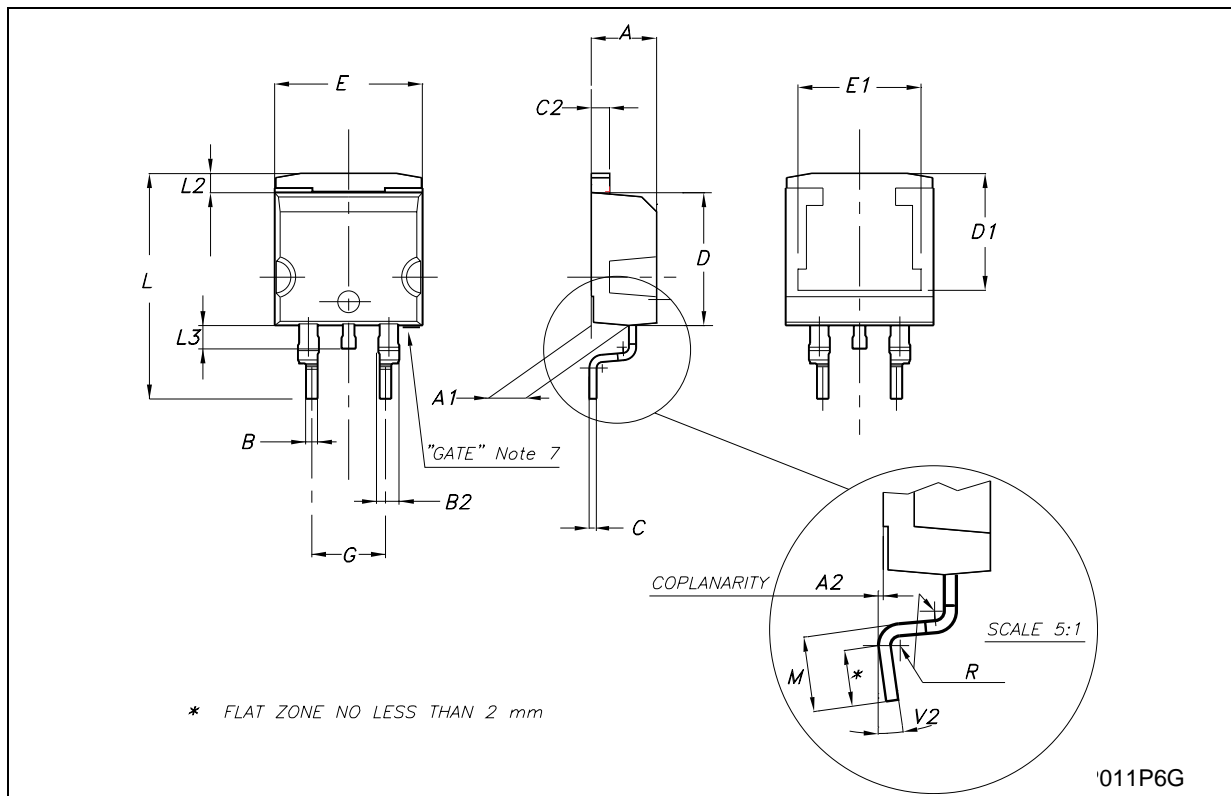

Tape & Reel D²PAK-P²PAK-D²PAK/A-P²PAK/A MECHANICAL DATA

DIM.	mm.			inch		
	MIN.	TYP	MAX.	MIN.	TYP.	MAX.
A			180			7.086
C	12.8	13.0	13.2	0.504	0.512	0.519
D	20.2			0.795		
N	60			2.362		
T			14.4			0.567
Ao	10.50	10.6	10.70	0.413	0.417	0.421
Bo	15.70	15.80	15.90	0.618	0.622	0.626
Ko	4.80	4.90	5.00	0.189	0.193	0.197
Po	3.9	4.0	4.1	0.153	0.157	0.161
P	11.9	12.0	12.1	0.468	0.472	0.476

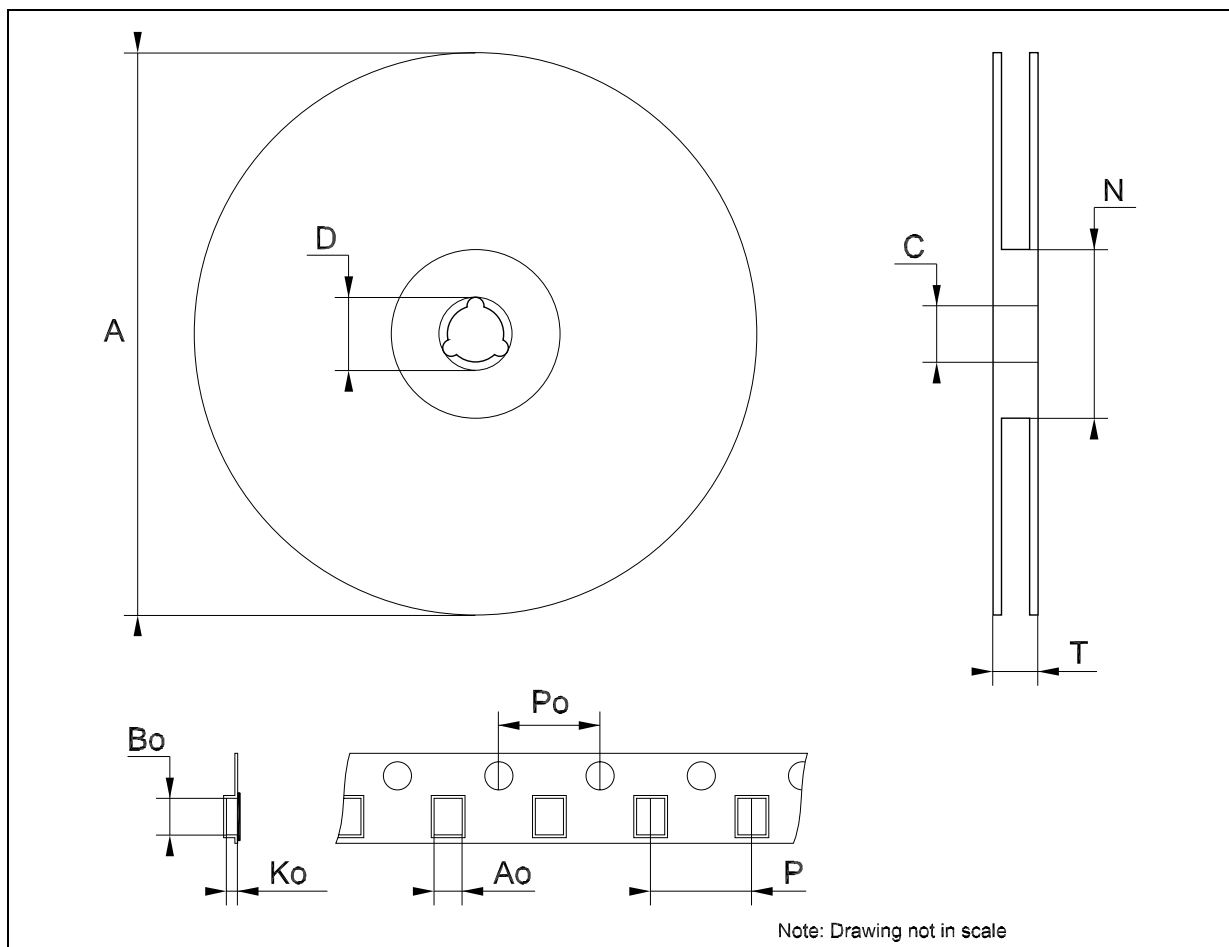

Information furnished is believed to be accurate and reliable. However, STMicroelectronics assumes no responsibility for the consequences of use of such information nor for any infringement of patents or other rights of third parties which may result from its use. No license is granted by implication or otherwise under any patent or patent rights of STMicroelectronics. Specifications mentioned in this publication are subject to change without notice. This publication supersedes and replaces all information previously supplied. STMicroelectronics products are not authorized for use as critical components in life support devices or systems without express written approval of STMicroelectronics.

The ST logo is a registered trademark of STMicroelectronics
All other names are the property of their respective owners

© 2004 STMicroelectronics - All Rights Reserved
STMicroelectronics GROUP OF COMPANIES

Australia - Belgium - Brazil - Canada - China - Czech Republic - Finland - France - Germany - Hong Kong - India - Israel - Italy - Japan -
Malaysia - Malta - Morocco - Singapore - Spain - Sweden - Switzerland - United Kingdom - United States.

<http://www.st.com>